

GTR-680

User Manual



TEL : 04-2238-0698

FAX : 04-2238-0891

Web Site : <http://www.monicon.com.tw>







E-mail : sales@monicon.com.tw

Introduction

Panel descriptions



Setup Keypad

-  — In password entry mode, this keypad switches to next digit.
— Under PARAMETER setting, this keypad switches to the next parameter.
-  — In password entry mode, this keypad switches to previous digit.
— Under PARAMETER setting, this keypad switches to previous parameter.
-  — In CODE entry mode, this keypad increases the value
Under PARAMETER setting, this keypad increases the setting value.
-  — In CODE entry mode, this keypad decreases the value.
— Under the PARAMETER setting mode, this keypad decreases the setting
-  — Enter or exit the parameter setting mode
-  — Confirm and save the settings
-  — These keypads alternately change the display of Genset information, evenlog, and error code.

Operational Keypad



1. **Manual** : In manual mode, the LCD shows pre-heat function; after pre-heat, engine starts immediately. If engine fails to start, the GTR-680 returns to the OFF mode. The pre-heat state may not perform, if parameter setting is disabled. If Pre-fuel is activated, the fuel outputs before crank procedure.
2. **AUTO** : In the Auto mode, the GTR-680 starts the engine by ATS signal and then the LCD shows preheat, if pre-heat function is enabled. After pre-heat, the engine starts to crank. If engine fails to start, the system returns to the pre-heat state and then start to crank the engine again. For example, if the conditions and parameter settings are given as follows: 1.stop duration is 10 seconds, crank attempt is 3 times. The engine cranks for 10 seconds and then rest for 10 seconds, after 3 attempts, the LCD shows the over crank and triggers the alarm.
3. **OFF** : Press OFF button stops the engine and then “stop” appears on the LCD. The idle also appears on the LCD, if the idle function is enabled. After 10 seconds of delay (depends on the setting), the engine stops completely and idle icon disappears.
RESET : When controller detects malfunction, system goes into protection mode and display error message on the LCD or LED indicator. Press and hold reset button to clear faults and reset alarm. The technician can start troubleshooting the faults.
4. **Light** : Press light button to test LED indicators.
5. **LOG** : Press LOG button to enter even logs.

Back Panel :

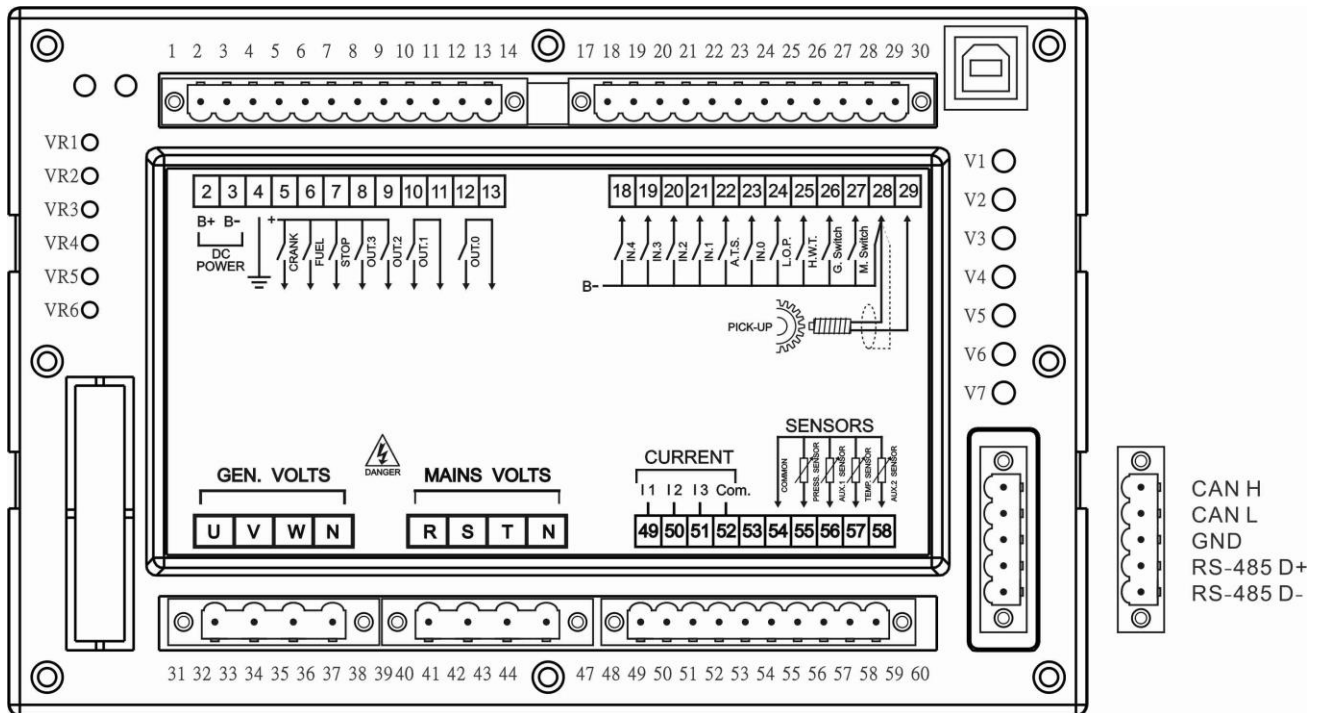

Pin	Description	Code
2	Battery +	B+
3	Battery -	B-
4	Ground	B_COM
5	Crank output	O_MOTOR
6	Fuel pump output	O_VALVE
7	Stop output	O_STOP
8	Preheat output	O_PREHEAT
9	Alarm output	O_ALARM
10	AUX output 1	O_OUT1 (N.O.)
11		
12	AUX output 0	O_OUT0 (N.O.)
13		
18	AUX input 4	IN.4
19	AUX input 3	IN.3
20	AUX input 2	IN.2
21	AUX input 1	IN.1
22	ATS input	A.T.S.
23	Emergency push button	IN.0
24	Low oil pressure switch	L. O. P.
25	High water temperature switch	H. W. T.
26	N/A	G. Switch

27	N/A	M . Switch
28	Pickup (RPM)	PICK-UP
29		
32	Generator U input	U
34	Generator V input	V
35	Generator W input	W
37	Generator N input	N
41	N/A	R
42	N/A	S
44	N/A	T
46	N/A	N
49	CT 1 input	I 1 (K)
50	CT 2 input	I 2 (K)
51	CT 3 input	I 3 (K)
52	CT Common input	Com.
53	Sensor V+ output	SENSOR V+
54	Sensor Common GND input	COMMON
55	Oil pressure sensor input	OIL PRESS.
56	Oil temperature sensor input	OIL TEMP.
57	Water temperature sensor input	COOLANT TEMP.
58	AUX sensor input	AUXILIARY
J1	CANBUS H	CAN H
J2	CANBUS L	CAN L
J3	CANBUS GND	CAN GND
J4	RS485 D+	RS485 D+
J5	RS485 D-	RS485 D-

Dimensions

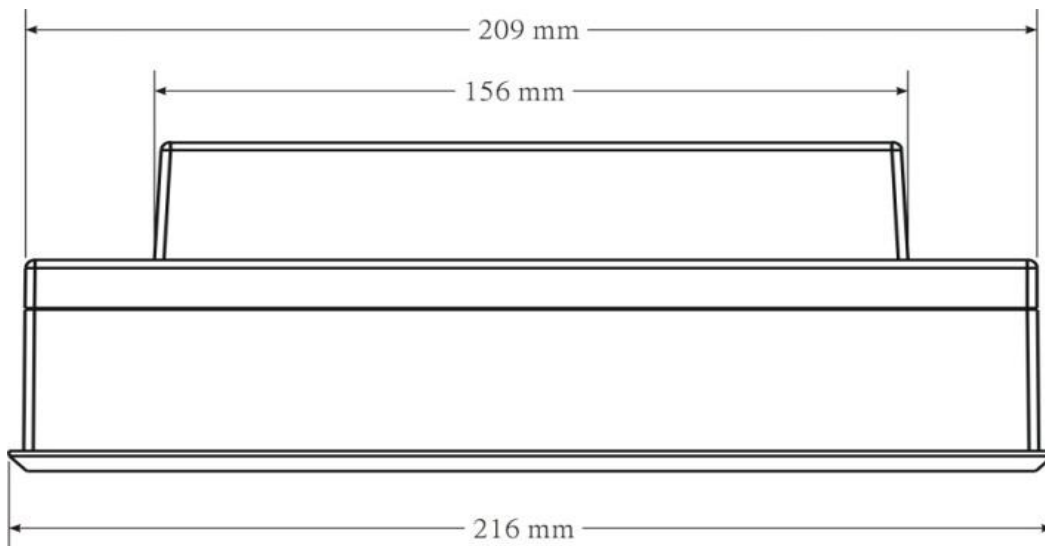
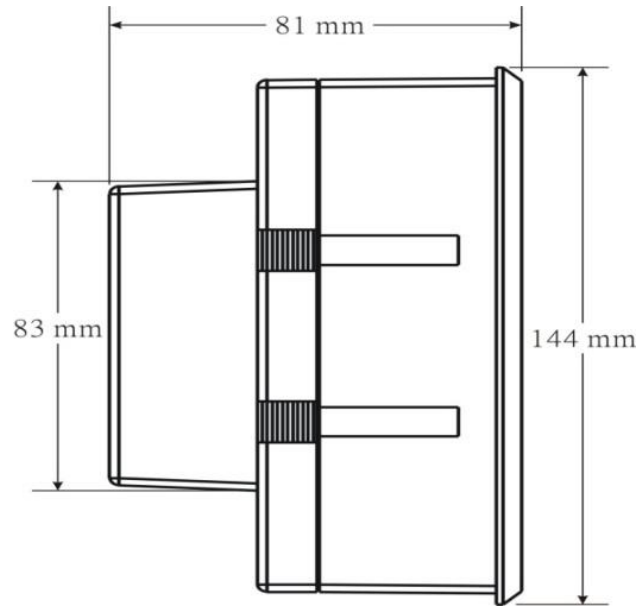

Functions

- **Settings**

- A. System setup
- B. Generator voltage
- C. Generator current
- D. Generator frequency
- E. Engine
- F. RPM
- G. Battery
- H. Exercisor
- I. Senesors
- J. Event logs
- K. Error logs

- **Remote Network:**

- 1. Start, stop, and reset
- 2. Parameter settings
- 3. Genset monitoring
- 4. Error records

- **Front Panel:**

- A. Manual / AUTO / OFF / RESET / LIGHT / LOGS
- B. Setup Keypads

● Protections

Engine

- 1.High water temperature
- 2.Low oil pressure
- 3.Low coolant
- 4.Over crank
- 5.Over speed
- 6.Low fuel

Generator

- 1.Over load
- 2.Short
- 3.High voltage
- 4.Low voltage
- 5.High frequency
- 6.Low requencey

Battery

- 1.Low voltage
- 2.High voltage
- 3.Charge fail
- 4.Under voltage

● . Specifications

DC input : 8~36 VDC

Power consumption : Max. 24 W

Voltage measurement : 0~500VAC(± 0.2 %)

Current measurement : 0~5 A * CT ratio (± 0.2 %)

Frequency measurement : 0~80 Hz(± 0.02 %)

Charger or pickup voltage : 5 V ~ 70 V(peak to peak)

Charger or pickup frequency : 62 Hz ~ 5KHz

Relay output : 10 A/30 VDC (Output 3 Max. 1 A).

Communication protocol : A. Power environment Communication protocol
B. Modbus master Communication protocol

Working temperature : -10 °C ~ 60 °C

Dimension(W * H * D) : 216 mm * 144 mm * 89 mm

Opening(W * H) : 210 mm * 138 mm

Weight : 1 Kg

A. Parameter Modify:

1.....

Crank Settings

1. Detect Frequency
Setting : Disable/ Enable
Default : Enable
Description : Check frequency value before cranking the engine.
2. Detect oil press
Setting : Disable/ Enable
Default : Enable
Description : Check oil pressure before cranking the engine.
3. Crank interval
Setting : 5~40(seconds)
Default : 10
Description : Set the duration of each crank.
4. Crank attempts
Setting : 1~10
Default : 3
Description : Set total number of crank attempts.
5. Escape up limit
Setting : 15~30(Hz)
Default : 20
Description : When frequency reaches setting, starter motor disconnects from engine.
6. Engage low limit
Setting : 15~30(Hz)
Default : 20
Description : If frequency is below setting allows crank procedure
7. OP build up time
Setting : 0.2~2.0(Seconds)
Default : 0.6
Description : Time delay before disconnecting starter motor after oil pressure switch activates. (“Detect oil press” must be enabled.)
8. Idle interval
Setting : 0~600(Seconds)
Default : 0
Description : Duration of engine idle

2.

Engine Settings

1. PreAdd Fuel Time
Setting : 0.0~5.0(seconds)
Default : 3
Description : Activates fuel pump before initiating crank procedure.
2. Pre-Heat Time
Setting : 0~20(Seconds)
Default : 0
Description : Duration of Preheat before crank.
3. Energied to Stop
Setting : 1~30(seconds)
Default : 10
Description : Output duration for stop solenoid to shut down the engine.
4. Failed to stop
Setting : 1~10(Seconds)
Default : 2
Description : Time delay before triggering engine shutdown failed alarm.
5. Trip then shut
Setting : Disable/ Enable
Default : Enable
Description : When error occurred, timer starts before shutdown the engine
6. Trip duration
Setting : 30~900(Seconds)
Default : 30
Description : When error occurred, controller outputs error signal, if error is not cleared within setting, system initiates Genset shutdown.
7. Cooling time
Setting : 0~1250(Seconds)
Default : 30
Description : Set engine cooling time for normal Genset shutdown. Engine cooling time is disabled during malfunction shutdown
8. Freq versus RPM
Setting : 0~200
Default : 30
Description: To conver RPM from frequency, divide RPM by frequency (1800rpm/60HZ=30), 30 is the ratio for this setting.
9. Man Inst. Stop

Setting : Disable/ Enable

Default : Enable

Description : Manual shutdown the Genset without cooling down the engine

3.

Hour Meters

1. Acc.: Seconds/
Setting : 0~59(Seconds)
Default : 0
Description : Set the hour meter in seconds.
2. Acc.: Minutes
Setting : 0~59(Minutes)
Default : 0
Description : Set the hour meter in minutes
3. Acc.: Hour
Setting : 0~99(Hour)
Default : 0
Description : Set the hour meter in hours.
4. Acc.: Hour * 100
Setting : 0~99(*100)
Default : 0
Description : Set the hour meter in 100 hours scale.

4.

Sensors Switches

1. H.W.T. Detection
Setting : Disable/ Enable
Default : Enable
Description : Activates high water temperature protection
2. H.T. Sw. Type
Setting : NC/NO
Default : Normal Open
Description : Setup the switch to normally close or normally open.
3. H.W.T. Sw. Delay
Setting : 1~9.5(Seconds)
Default : 1.5
Description : When high water temperature occurs, timer starts before initiating shutdown.
4. L.O.P. Detection
Setting : Disable/ Enable
Default : Enable

Description : Activates low oil pressure protection

5. O.P. Sw. Type

Setting : NC/NO

Default : Norma close

Description : Setup the switch to normally close or normally open.

6. L.O.P Sw. Delay

Setting : 0.2~6.0(Seconds)

Default : 1

Description : When low oil pressure occurs, timer starts before initiating shutdown.

5.

Auxiliary Input

1. Auto input delay

Setting : 0.2~5(seconds)

Default : 1

Description : Time delay for ATS input before initiating crank procedure.

2. Input0 Detect

Setting : Disable/ Enable

Default : Enable

Description : Activates Input 0 function

3. Input 0 Name

Setting : 1.Emergency Stop 2.User Define 3.Low battery Voltage 4. System fault 5.High fuel level 6. System trip 7.Insulation Fail 8.Cooling failure 9.Malfunction warning 10.Charge fail 11.Over load 12.Low water temperature 13.Preheat

Default : Preheat

Description : Define the function for input 0

4. In0 Protection

Setting : 1.Warning 2.Alarm 3.Trip 4.Stop)

Default : Stop.

Description : Setup the action when input 0 activates

5. In0 Switch Type

Setting : NC/NO

Default : Normal Close

Description : Setup input 0 to normally close or normally open

6. Input0 Delay

Setting : 0.2~5.0(Seconds)

Default : 0.2

Description : When input0 activates, timer starts before activating protection

7. Input 1 Detect

- Setting : Disable/ Enable
Default : Enable
Description : Activates input1 function
8. Input1 Name : 1.Emergency Start 2.User Define 3.Low battery Voltage 4. System fault
5.High fuel level 6. System trip 7.Insulation Fail 8.Cooling failure 9.Malfunction warning
10.Charge fail 11.Over load 12.Low water temperature 13.Preheat
Default : 4.
Description : Define function for input 1
9. In1 Protection
Setting : 1.Warning 2.Alarm 3.Trip 4.Stop
Default : Stop
Description : Setup the action when input1 activates
10. In1 Switch Type
Setting : NC/NO
Default : Normal Open
Description : Define input1 type to normally close or normally open
11. In1 delay
Setting : 0.2~5.0(Seconds)
Default : 2.0
Description : When input1 activates, timer starts before activating protection
12. Input 2 Detect
Setting : Disable/ Enable
Default : Enable
Description : Activates input2 function
13. Input 2 Name
Setting : 1.Low coolant level 2.User Define 3.Low battery Voltage 4. System fault 5.High
fuel level 6. System trip 7.Insulation Fail 8.Cooling Fan failure 9.Malfunction warning
10.Charge fail 11.Over load 12.Low water temperature 13.Preheat
Default : 8.
Description : Define function for input 2
14. In2 Protection
Setting : 1.Warning 2.Alarm 3.Trip 4.Stop
Default : 2
Description : Setup the action when In2 activates
15. In2 switch type
Setting : NC/NO
Default : Normal Open
Description : Setup input2 to normally close or normally open

16. Input2 Delay
Setting : 0.2~5.0(Seconds)
Default : 0.4
Description : When input2 activates, timer starts before activating protection
17. Input3 Detect
Setting : Disable/ Enable
Default : Enable
Description : Activates input3 function
18. Input 3 Name
Setting : 1.Low fuel level 2.User Define 3.Low battery Voltage 4. System fault 5.High fuel level 6. System trip 7.Insulation Fail 8.Cooling Fan failure 9.Malfunction warning 10.Charge fail 11.Over load 12.Low water temperature 13.Preheat
Default : 6.
Description : Define function for AUX 3
19. In3 Protection
Setting : 1.Warning 2.Alarm 3.Trip 4.Stop
Default : 4.
Description : Setup the action when input 3 activates
20. In3 Switch Type
Setting : NC/NO
Default : Normal Open
Description : Setup Input 3 to normally close or normally open
21. Input3 Delay
Setting : 0.2~5.0(Seconds)
Default : 2
Description : When input 3 activates, timer starts before activating protection
22. Input4 Detect
Setting : Disable/ Enable
Default : Enable
Description : Activates input4 function
23. Input4 Name
Setting : 1.Low fuel level 2.User Define 3.Low battery Voltage 4. System fault 5.High fuel level 6. System trip 7.Insulation Fail 8.Cooling Fan failure 9.Malfunction warning 10.Charge fail 11.Over load 12.Low water temperature 13.Preheat
Default : 5.
Description : Define function for input4
24. In4 Protection
Setting : 1.Warning 2.Alarm 3.Trip 4.Stop
Default : 2.

Description : Setup the action when input 4 activates

25. In4 Switch Type

Setting : NC/NO

Default : Normal Open

Description : Setup Input 4 to normally close or normally open

26. Input4 Delay

Setting : 0.2~5.0(Seconds)

Default : 0.4

Description : When input 4 activates, timer starts before activating protection

6.

Auxiliary Output

1. Output 0 function

Setting : 1~45

1.All errors	2. Trip	3.Preheat	4.Idle
5.Reset	6.Main breaker On	7.Main breaker hold	8. Genset power normal
9.Engine running	10.Over crank	11.Over speed	12.Over frequency
13.Low frequency	14.Low oil pressure(switch)	15. High water temperature(switch)	16.High AC voltage
17.Low AC voltage	18.Overload	19.Short circuit	20.Low battery voltage
21.High battery voltage	22.Input 0 activate	23.Input 1 activate	24.Input 2 activate
25. Input 3 activate	26.Sensor fault	27.High water temp.	28.Low oil pressure
29.Low fuel level	30.High fuel level	31.System not in AUTO	32.System in AUTO
33.Manual Start	34.AUTO Start	35.Standby mode	36.Pre-heat
37.Pre-fuel	38.Cranking	39.Crank cycle	40.System normal
41.System Alarm	42.System Trip	43.Engine shutdown	44.Engine Cooling
45. Reverse power			

Default : 36.

Description : Setup the function for output 0

2. Output 1 function

Setting : 1~45

Default : 1.

Description : Setup the function for output 1

3. Output 2 function

Setting : 1~45

Default : 5.

Description : Setup the function for output 2

4. Output 3 function

Setting : 1~45

Default : 42.

Description : Setup the function for output 3

7.

CAN Bus J1939

1. J1939 Function

Setting : Disable/ Enable

Default : Enable

2. ECU Brand

Setting :

Caterpillar	Cummins	Chrysler	Detroit Diesel	Deutz	GM
Isuzu	Iveco	JCB	John Deere	Logger	MAN
MTU	Perkins	Scania	SISU	Standard	Steyer
VM	Volvo				

Description : Setup brand and model of the ECU

3. RPM Command

Setting : Disable/ Enable

Default : Enable

4. Idle Speed

Setting : 900 RPM

Description : Set idle speed

5. Rated Speed

Setting : 1800 RPM

Description : Set rated speed

6. Display Hour Meter from ECU

Setting : Disable/ Enable

Default : Disable

8. **F**

requency

1. System Frequency

Setting : 50/60(Hz)

Default : 60

Description : Setup Genset frequency in 50Hz or 60Hz

2. Hi Freq. Detect

Setting : Disable/ Enable

Default : Enable

Description : Activates high frequency protection

3. H.F. set point
 Setting : 50~60/60~72(Hz)
 Default : 55/66Hz
 Description : When AC frequency is higher than setting, controller shuts down the engine and display high frequency error, if high frequency protection is enable.
4. Hi Freq. Delay
 Setting : 1~9(Seconds)
 Default : 1
 Description : When high frequency occurs, timer starts before activating protection
5. Low frequency Detect
 Setting : Disable/ Enable
 Default : Enable
 Description : Activates low frequency protection
6. L.F. Protection
 Setting : 1.Warning 2.Alarm 3.Trip 4.shutdown
 Default : 2
 Description : Setup the action when low frequency occurs
7. L.F Set Point
 Setting : 40~50/48~60(Hz)
 Default : 45/55Hz
 Description : When AC frequency is lower than setting, controller outputs trip signal.
8. Low Freq. Delay
 Setting : 1~9(seconds)
 Default : 3
 Description : When low frequency occurs, timer starts before activating protection
9. Mini. Freq. Det
 Setting : Disable/ Enable
 Default : Enable
 Description : Activates minimum low frequency protection.
10. M.F. set point
 Setting : 30~48(Hz)
 Default : 36
 Description : When sudden drop of frequency belows setting; low frequency protection automatically disables and engine operates at idle speed.

9.

Battery

1. System DC volt
 Setting : 12/24(V)

Default : 12

Description : Setup DC voltage in 12V or 24V

2. Batt. Fault Alarm

Setting : Disable/ Enable

Default : Enable

Description : Activates battery error protections

3. L batt Set Point

Setting : 8.4~12/16.8~24(V)

Default : 10.8/20

Description : When battery voltage is below setting, controller displays low DC volt warning.

4. H batt Set Point

Setting : 12~16.8/24~33.6(V)

Default : 14.4/28.4

Description : When battery voltage is above setting, controller displays high DC volt warning.

5. Weak Batt. Detect

Setting : Disable/ Enable

Default : Enable

Description : Activates weak battery protection

6. W. Batt. Set Point

Setting : 4.8~8.4/9.6~16.8(V)

Default : 8.4/9.6

Description : When battery voltage is below setting, controller displays battery warning.

7. Charge failed

Setting : 9.6~14.4/19.2~28.8(V)

Default : 12.6/22.6V

Description : When voltage is out of range, controller displays charge fail.

10.

AC Voltage

1. System AC Volt

Setting : 110/120/190/208/220/380V/440/480/660/3300/4160/6600/7620/11400

Default : 380V

Description : Setup Genset AC voltage

2. Hi ACV Protect

Setting : Disable/ Enable

Default : Enable

Description : Activates high voltage protection.

3. Hi ACV Protection
Setting : 1.Warning 2.Alarm 3.Trip 4.Stop
Default : 3
Description : Setup the action when high voltage occurs.
4. Hi ACV Set Point
Setting : 110~132/120~144/190~228/208~250/220~264/380~456(V)
Default : 122/122/210/242/242/418
Description : When AC voltage is above the setting, the controller outputs trip signal.
5. Hi ACV Delay
Setting : 0.5~5(Seconds)
Default : 2.5
Description : When high voltage occurred, timer starts before activating protection
6. Low ACV Detect
Setting : Disable/ Enable
Default : Enable
Description : Activates low voltage protection
7. Low ACV Protection
Setting : 1.Warning 2.Alarm 3.Trip 4.Stop
Default : 3
Description : Setup the action when low voltage occurs
8. Low ACV set point
Setting : 78~110/84~120/134~190/146~208/154~220/266~380(V)
Default : 108/108/172/198/198/342
Description : When AC voltage is below setting, controller outputs trip signal
9. Low ACV delay
Setting : 0.5~5(Seconds)
Default : 2.5
Description : When low voltage occurred, timer starts before activating protection
10. Mini. ACV Detect
Setting : Disable/ Enable
Default : Enable
Description : Activates extreme low voltage protection.
11. Mini. ACV setpoint
Setting : 34~88/36~96/58~152/62~166/66~176/114~304(V)
Default : 56/60/96/110/110/198
Description : When sudden drop of AC voltage blows setting, low voltage protection is disabled.
12. ACV Escape Motor

Setting : Disable/ Enable

Description : Disconnect starter motor by Genset voltage

13. Esc. ACV Setpoint

Setting : 44~100/48~108/76~172/84~188/88~198/152~342(V)

Default : 72/72/124/124/132/228

Description : Disconnect starter motor when AC Voltage reaches disconnecting setting

11.

AC Ampere

1. Current Ratio:

Range : 1~31

5:5	10:5	15:5	20:5	30:5
40:5	50:5	60:5	75:5	80:5
100:5	150:5	200:5	250:5	300:5
400:5	500:5	600:5	700:5	800:5
900:5	1000:5	1200:5	1500:5	1600:5
2000:5	2500:5	3000:5	3200:5	4000:5
5000:5				

Default : 500:5

Description : Setup the current transformer ratio

2. Over load Detect :

Setting : Disable/ Enable

Default : Enable

Description : Activates overload protection

3. Over load Protection :

Setting : 1.Warning 2.Alarm 3.Trip 4.Stop

Default : 3

Description : Setup the action when overload occurs

4. O. L. Set Point :

Range : 1~31

0.1~20.0(A)	0.1~30.0(A)	0.1~40.0(A)	0.1~50.0(A)	0.1~60.0(A)
0.1~75.0(A)	0.1~80.0(A)	0.2~100.0(A)	0.3~150.0(A)	0.4~200.0(A)
5.0~250.0(A)	6.0~300.0(A)	8.0~400.0(A)	10.0~500.0(A)	12.0~600.0(A)
14~700.0(A)	15.0~750.0(A)	16.0~800.0(A)	18.0~900.0(A)	20.0~1000.0(A)
24.0~1200.0(A)	30.0~1500.0(A)	32.0~1600.0(A)	40.0~2000.0(A)	50.0~2500.0(A)
60.0~3000.0(A)	64.0~3200.0(A)	80.0~4000.0(A)	100.0~5000.0(A)	120~6000(A)

Description : When current is above setting, the controller outputs trip signal, setup range is related to the CT ratio.

5. Overload Delay :

Setting : 10~300(Second)

Default : 40

Description : When overload occurs, timer starts before activating protection

6. Short Detect :

Setting : Disable/ Enable

Default : Enable

Description : Activates AC short protection

7. Short protect:

Setting : 1.Warning 2.Alarm 3.Trip 4.Stop)

Default : 4

Description : Setup the action when AC short occurs

8. Short Set Point :

Setting : 1~31

1~5(A)	2~10(A)	3~15(A)	4~20(A)	6~30(A)
8~40(A)	10~50(A)	12~60(A)	15~75(A)	16~80(A)
20~100(A)	30~150(A)	40~200(A)	50~250(A)	60~300(A)
80~400(A)	100~500(A)	120~600(A)	150~750(A)	160~800(A)
180~900(A)	200~1000(A)	240~1200(A)	300~1500(A)	320~1600(A)
400~2000(A)	500~2500(A)	600~3000(A)	640~3200(A)	800~4000(A)
1000~5000(A)				

Description : When current is above the setting, controller outputs trip signal, setup range is related to the CT ration setup.

9. Short Delay :

Setting : 0.1~1.0(Second)

Default : 0.2

Description : When AC short occurs, timer starts before activating protection

12.

RPM

1. RPM Mul. Factor

Setting : 1~200

Default : 60

Description : Please use value calculated in next parameter setting

2. RPM Div. Factor

Setting : 1~200

Default : 40

Description : The R.P.M. Mul. and Div. are the ratio of engine revolution versus total number

of fly wheel teeth; or the RPM of fly wheel versus the RPM of alternator charger. For example: Set up the RPM numerator and the denominator to 1 to find input pulse from the LCD.

(A) If the engine revolution is 1800 and alternator revolution is 460 (input pulse), the R.P.M. numerator could be set to 90 → (1800 ÷ 20) and R.P.M. denominator could be set to 23 → (460 ÷ 20).

Solution: $1800 / 460 = 3.913$

The R.P.M. calculation formula is as below

R.P.M. = Input pulse * (RPM numerator / RPM denominator)

$$1800 = 460 * (90/23)$$

(B) If the engine revolution is 1500 and total count of fly wheel teeth in one second is 4437 (input pulse), the R.P.M. numerator should be set to 45 and R.P.M. denominator should be set to 133.

Solution: $1500 / 4437 = 0.338$

The R.P.M. calculation formula is as below

R.P.M. = Input pulse * (revolution numerator / revolution denominator)

$$1500 = 4437 * (45/133)$$

(C) If the teeth count of engine flywheel is 118. Assume the rated rpm of Gen-set is 1500 rpm. Then the 1500 rpm/50hz => 30 rpms/per second also generate 30 x 118 =3540 electronic signals. Then $1500 / 3540 = 0.423$ ($75/177=0.423$), set the R.P.M. numerator to 75 and R.P.M. denominator to 177.

3. RPM Escape motor

Setting : Disable/ Enable

Default : Disable

Description : Disconnect starter motor by RPM setting

4. RPM Esc. Set point

Setting : 300~900(RPM)

Default : 480

Description : Disconnect starter motor when RPM reaches setting

5. RPM Disp. Source

Setting : Alternator / Frequency

Default : Freq.

Description : Converts the RPM from frequency or alternator speed.

6. O.S. Detection

Setting : Disable/ Enable

Default : Enable

Description : Activates over speed protection.

7. O.S. set point

Setting : 1350~2100(RPM)

Default : 1980

Description : If engine speed is higher than setting, controller shuts down the engine only if

over speed is enabled

8. Over speed delay

Setting : 1~10(Second)

Default : 1

Description : When over speed occurs, timer starts before activating protection

13.

Sensors

1. LFL Value Alarm

Setting : Disable/ Enable

Default : Enable

Description : Activates low fuel warning

2. LFL set point

Setting : 6~55(%)

Default : 45

Description : When fuel level is below setting, controller displays warning message.

3. HFL set point

Setting : 35~99(%)

Default : 95

Description : When fuel level is above setting, controller displays warning message

4. LOP value alarm

Setting : Disable/ Enable

Default : Enable

Description : Activates low oil pressure warning

5. LOP set point

Setting : 15~60(Psi)

Default : 15

Description : When oil pressure is below setting, controller displays warning message

6. HWT Value Alarm

Setting : Disable/ Enable

Default : Enable

Description : Activates high water temperature protection.

7. HWT set point

Setting : 85~110(°C)

Default : 105

Description : When water temperature is above setting, controller displays warning message

8. OP Escape motor

Setting : Disable/ Enable

Default : Disable

Description : Disconnect starter motor when oil pressure reaches setting.

9. Esc. OP Set point

Setting : 25~65(Psi)

Default : 45

Description : Disconnect starter motor when oil pressure reaches setting.

10. OP Sensor Brand

Setting :

VDO 10 Bar	KD 10 Bar	YG 962	N 010 B2	KL 3967251
MHI 10 Bar	DATCON 10 Bar	SUSUKI 10 Bar	VDO 5 Bar	KP 6 Bar
KAMAZ	Betung	Weichai	Betung 3317-EPT	

Description : Setup oil pressure sensor brand.

11. WT sensor Brand

Setting :

VDO 120	KD 120	WGI 900131	KP130	YB 054
KL 3967250	MHI 98	SUSUKI	PRO	SCD
Betung	User Define			

Description : Setup water temperature sensor brand

12. FL sensor Brand

Setting :

SUSUKI	Betung	User Define
--------	--------	-------------

Description : Setup fuel sensor brand

13. Check before start

Setting : Disable/ Enable

Default : Disable

Description : Setup the system to check sensors during controller boot up.

14. Cel. Or Feh

Setting : °F / °C

Default : °C

Description : Setup water temperature unit in Fahrenheit or Celsius.

15. P.S.I or Bar

Setting : BAR /PSI

Default : PSI

Description : Setup oil pressure unit in Bar or PSI

14.

Exerciser funct.

1. Exercise Funct.

Setting : Disable/ Enable

- Default : Enable
- Description : Activates exerciser function.
- 2. Date/ week Depend
 - Setting : Date/Week
 - Default : Date
 - Description : Setup monthly exercise by date or week.
- 3. Date set point
 - Setting : 1~31(date)
 - Default : 28
 - Description : Setup date of monthly exercise
- 4. Week set point
 - Setting : Sunday/Monday/Tuesday/Wednesday/Thursday/Friday/saturday
 - Default : Sunday
 - Description : Setup week of monthly exercise
- 5. Hour set point
 - Setting : 0~23(hour)
 - Default : 12
 - Description : Setup the starting hour of the exercise
- 6. Minute set point
 - Setting : 0~59(minute)
 - Default : 0
 - Description : Setup the starting minute of the exercise
- 7. Running Interval
 - Setting : 0~510(minute)
 - Default : 4
 - Description : Setup the duration of each exercise

15.

Maintain

- 1. Maintain Funct.
 - Setting : Disable/ Enable
 - Default : Disable
 - Description : Activates service reminder function
- 2. Maintain Protect
 - Setting : 1.Warning 2.Alarm 3.Trip 4.Stop
 - Default : 4
 - Description : Setup the action when service reminder reaches setting
- 3. Maintain Code 0
 - Setting : 0~99

Default : 12

Description : Setup first two digits of service password

4. Maintain Code 1

Setting : 0~99

Default : 15

Description : Setup remaining digits of service password

5. Maintain DnCount

Setting : 0~1275(hour)

Default : 250

Description : Setup the duration between each service

16.

OverLoad Protect

1. Over Load Detect

Setting : Disable/ Enable

Description : Activates over load detection.

2. Overload protect

Setting : 1.Warning 2.Alarm 3.Trip 4.Stop

Description : Setup the action when over load occurred

3. O. Load Setpoint

Setting :

0.08~20.0(KW)	0.1~30.0(KW)	0.1~40.0(KW)	0.1~50.0(KW)	0.1~60.0(KW)
0.1~75.0(KW)	0.1~80.0(KW)	0.2~100.0(KW)	0.3~150.0(KW)	0.4~200.0(KW)
5.0~250.0(KW)	6.0~300.0(KW)	8.0~400.0(KW)	10.0~500.0(KW)	12.0~600.0(KW)
14~700.0(KW)	15.0~750.0(KW)	16.0~800.0(KW)	18.0~900.0(KW)	20.0~1000.0(KW)
24.0~1200.0(KW)	30.0~1500.0(KW)	32.0~1600.0(KW)	40.0~2000.0(KW)	50.0~2500.0(KW)
60.0~3000.0(KW)	64.0~3200.0(KW)	80.0~4000.0(KW)	100.0~5000.0(KW)	120~6000(KW)

Description : Setup the Earth fault amperage limit

4. Over Load Delay

Setting : 1~20(Seconds)

Description : When Earth fault reaches setting, timer starts before activating protection

17.

Others

1. Protect Pending

Setting : 1~30 (seconds)

Default : 10

Description : Time delay for displaying warning or error messages after engine starts.

2. Language
 Setting : English/Chinese
 Default : English
 Description : Choose between English or Chinese language
3. Comm. Address
 Setting : 0~255(00H~FFH)
 Default : FFH
 Description : Multiple Genset networking via RS-485 requires individual address for each controller.
4. Not in AUTO Mode
 Setting : Disable/ Enable
 Description : When GTR-220 is in OFF mode, controller triggers alarm.
5. Contrast Adjust
 Setting: 1~19
 Description : Adjust contrast of LCD screen

18.....

Utility Charge

1. Cgr. In. Volt Low
 Setting : 100~198
 Default : 100
 Description: Setup utility
2. Cgr. In. Volt High
 Setting : 110~242
 Default : 100
 Description: Setup utility
3. Util.Charge Fail
 Setting : 1.Warning 2.Alarm 3.Trip 4.Stop
 Default : 2
 Description : Setup utility fail protection.

B. Error Record: Display Malfunction history

C. Miscellaneous

1. Time setting :
 Description : Setup real time clock
2. User Code :
 Description : Reset user password
3. Maintain Code :
 Description : Reset engineer password

4. Crank information :

Description :

- a. Total count: Display total number of crank attempts.
- b. Fail count: Display total number of crank fail.
- c. Succeed count: Display total number of successful cranks.
- d. .Reset counters: Clears crank information(Password required)

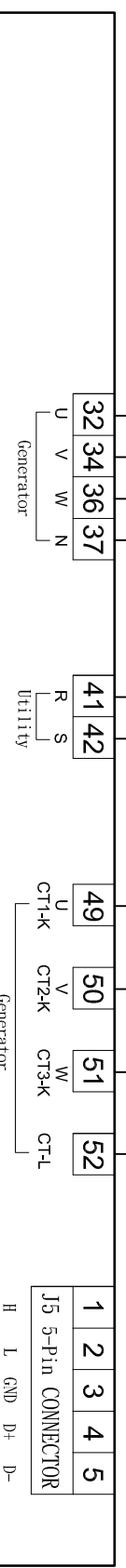
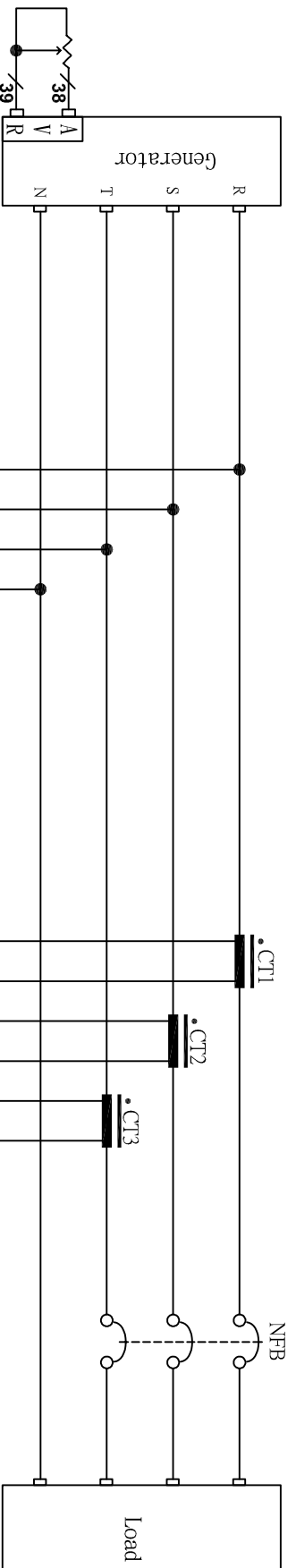

GTR-680 Controller

